

Monolithic Quad SPST Analog Switches

Features

- $\pm 15\text{-V}$ Input Range
- Low Off Leakage— $I_{D(on)}$: 0.1 nA
- Low On-Resistance— $r_{DS(on)}$: 115 Ω
- 44-V Maximum Supply Ratings
- TTL and CMOS Compatible

Benefits

- Wide Input Range
- Low Distortion Switching
- Can Be Driven from Comparators or Op Amps Without Limiting Resistors

Applications

- Disk Drives
- Radar Systems
- Communications Systems
- Sample-and-Hold

Description

The DG201A and DG202 are quad SPST analog switches designed to provide accurate switching over a wide range of input signals. When combining a low on-resistance and a wide signal range ($\pm 15\text{ V}$) with low charge-transfer these devices are well suited for industrial and military applications.

conducts equally well in both directions when on. When off these switches will block up to 30 V peak-to-peak and have a 44-V absolute maximum power supply rating.

These two devices are differentiated by the type of switch actions (See Truth Table).

Built on Siliconix' high voltage metal gate process to achieve optimum switch performance, each switch

The DG201B/DG202B upgrades are recommended for new designs.

Functional Block Diagram and Pin Configuration

DG201A

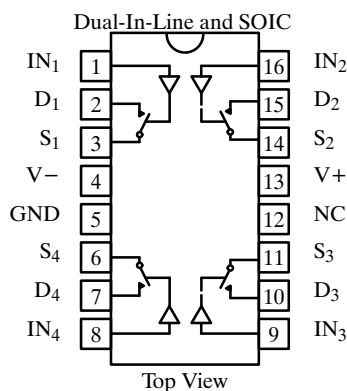

DG201A

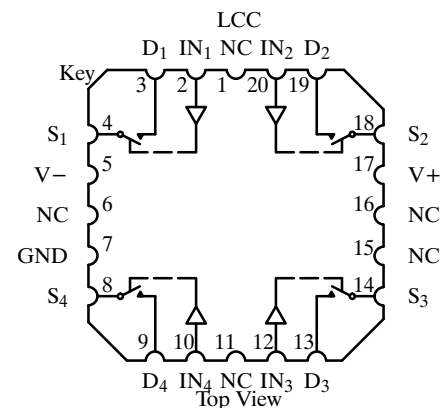

Ordering Information – DG201A/202

Temp Range	Package	Part Number
0 to 70°C	16-Pin Plastic DIP	DG201ACJ/DG202CJ
-25 to 85°C	16-Pin CerDIP	DG201ABK
-40 to 85°C	16-Pin Narrow SOIC	DG201ADY
-55 to 125°C	16-Pin CerDIP	DG201AAK
		DG201AAK/883, JM38510/12302BEA
		7705301EA
		DG202AK/DG202AK/883
	16-Pin Sidebrazed	JM38510/12302BEC
		7705301EC
LCC-20	DG201AAZ/883, 77053012A	

Truth Table

Logic	DG201A	DG202
1	OFF	ON

Logic "0" $\leq 0.8\text{ V}$
 Logic "1" $\geq 2.4\text{ V}$ Switches Shown for DG201A Logic "1" Input

DG201A/202

Absolute Maximum Ratings

Voltages Referenced to V-

V+	44 V
GND	25 V
Digital Inputs ^a V _S , V _D	(V-) -2 V to (V+) +2 V or 20 mA, whichever occurs first
Current, Any Terminal Except S or D	30 mA
Continuous Current, S or D	20 mA
Peak Current, S or D (Pulsed at 1 ms, 10% duty cycle max)	70 mA
Storage Temperature (K, Z Suffix)	-65 to 150°C
(J, Y Suffix)	-65 to 125°C

Power Dissipation (Package)^b

16-Pin Plastic DIP ^c	470 mW
16-Pin SOIC ^d	640 mW
16-Pin CerDIP and Sidebrazed ^e	900 mW
LCC-20 ^f	750 mW

Notes

- Signals on S_X, D_X, or IN_X exceeding V+ or V- will be clamped by internal diodes. Limit forward diode current to maximum current ratings.
- All leads welded or soldered to PC Board.
- Derate 6.5 mW/°C above 25°C
- Derate 7.6 mW/°C above 75°C
- Derate 12 mW/°C above 75°C
- Derate 10 mW/°C above 75°C

Specifications^a

Parameter	Symbol	Test Conditions Unless Otherwise Specified V+ = 15 V, V- = -15 V V _{IN} = 2.4 V, 0.8 V ^f	Temp ^b	Typ ^c	A Suffix -55 to 125°C		B, C, D Suffix		Unit
					Min ^d	Max ^d	Min ^d	Max ^d	
Analog Switch									
Analog Signal Range ^e	V _{ANALOG}		Full		-15	15	-15	15	V
Drain-Source On-Resistance	r _{DS(on)}	V _D = ±10 V, I _S = 1 mA	Room	115		175		175	Ω
			Full			250		250	
Source Off Leakage Current	I _{S(off)}	V _S = ±14 V, V _D = ∓14 V	Room Full	±0.02	-1 -100	1 100	-5 -100	5 100	nA
Drain Off Leakage Current	I _{D(off)}	V _D = ±14 V, V _S = ∓14 V	Room Full	±0.02	-1 -100	1 100	-5 -100	5 100	
Drain On Leakage Current	I _{D(on)}	V _S = V _D = 14 V	Room Full	±0.15	-1 -200	1 200	-5 -200	5 200	
Digital Control									
Input Current with Input Voltage High	I _{INH}	V _{IN} = 2.4 V	Room Full	-0.0004	-1 -1		-1 -10		μA
		V _{IN} = 15 V	Room Full	0.003		1 10		1 10	
Input Current with Input Voltage Low	I _{INL}	V _{IN} = 0 V	Room Full	-0.0004	-1 -10		-1 -10		
Dynamic Characteristics									
Turn-On Time	t _{ON}	See Switching Time Test Circuit	Room	480		600		600	ns
Turn-Off Time	t _{OFF}		Room	370		450		450	
Charge Injection	Q	C _L = 1000 pF, V _g = 0 V R _g = 0 Ω	Room	20					pC
Source-Off Capacitance	C _{S(off)}	V _S = 0 V, V _{IN} = 5 V, f = 1 MHz	Room	5					pF
Drain-Off Capacitance	C _{D(off)}		Room	5					
Channel On Capacitance	C _{D(on)} + C _{S(on)}	V _D = V _S = 0 V, V _{IN} = 0 V f = 1 MHz	Room	16					pF
Off Isolation	OIRR	V _{IN} = 5 V, R _L = 75 Ω V _S = 2 V, f = 100 kHz	Room	70					dB
Channel-to-Channel Crosstalk	XTALK		Room	90					

Specifications^a (Cont'd)

Parameter	Symbol	Test Conditions Unless Otherwise Specified $V_+ = 15\text{ V}, V_- = -15\text{ V}$ $V_{IN} = 2.4\text{ V}, 0.8\text{ V}^f$	Temp ^b	Typ ^c	A Suffix -55 to 125°C		B, C, D Suffix		Unit
					Min ^d	Max ^d	Min ^d	Max ^d	
Power Supply									
Positive Supply Current	I+	All Channels On or Off	Room	0.9		2		2	mA
Negative Supply Current	I-		Room	-0.3	-1		-1		

Notes

- a. Refer to PROCESS OPTION FLOWCHART (Section 5 of the 1994 Data Book or FaxBack number 7103).
- b. Room = 25°C, Full = as determined by the operating temperature suffix.
- c. Typical values are for DESIGN AID ONLY, not guaranteed nor subject to production testing.
- d. The algebraic convention whereby the most negative value is a minimum and the most positive a maximum, is used in this data sheet.
- e. Guaranteed by design, not subject to production test.
- f. V_{IN} = input voltage to perform proper function.

Typical Characteristics

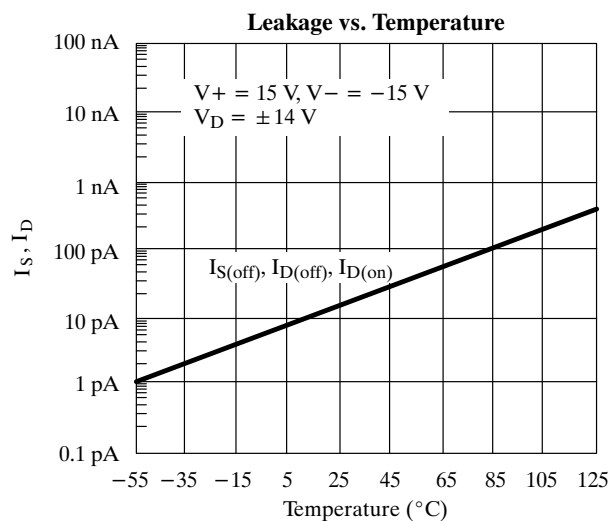
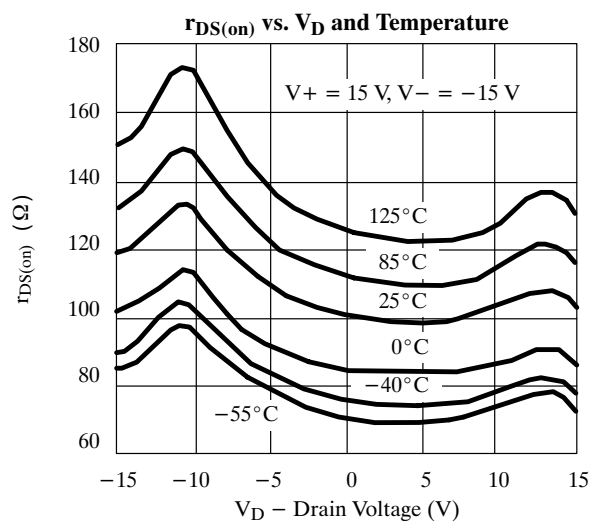
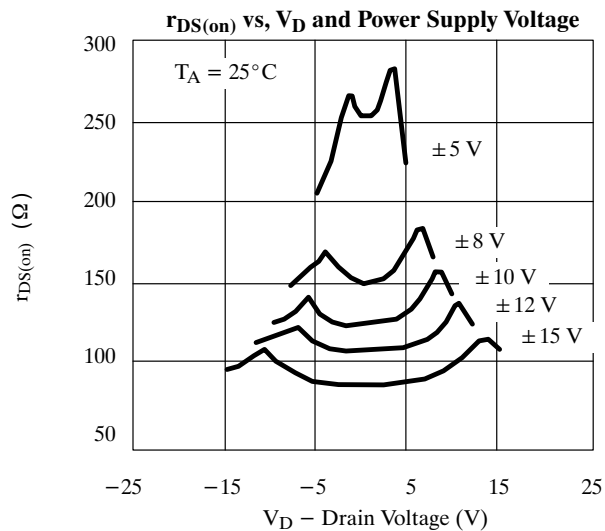
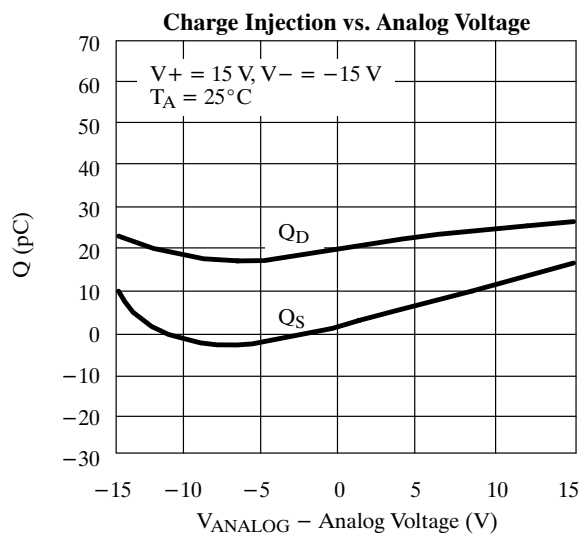

DG201A/202

Typical Characteristics (Cont'd)

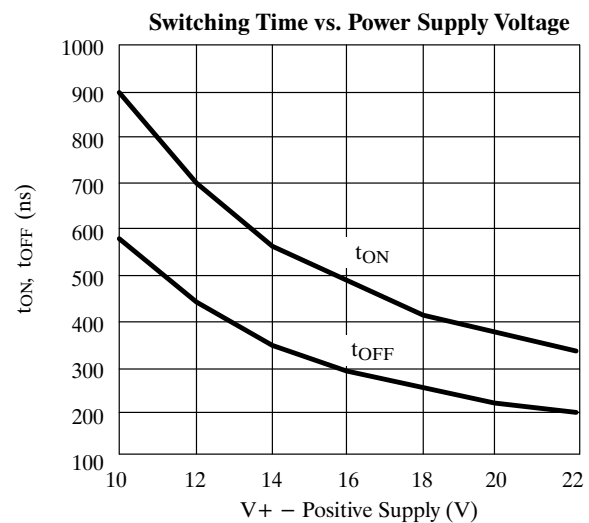
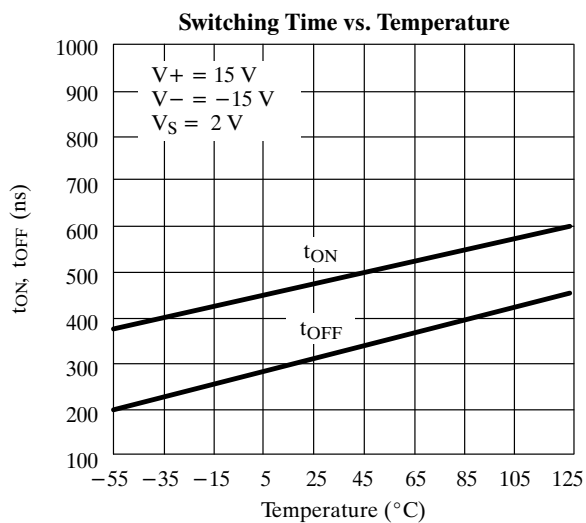
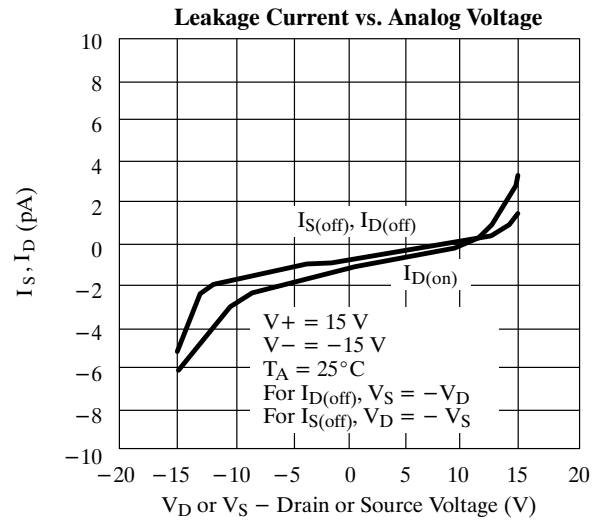
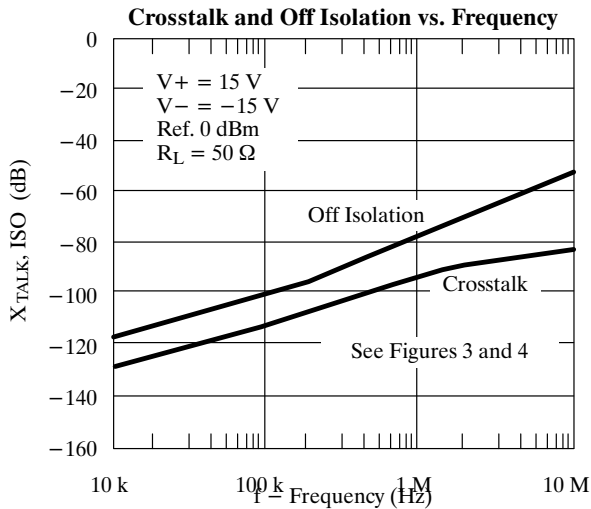
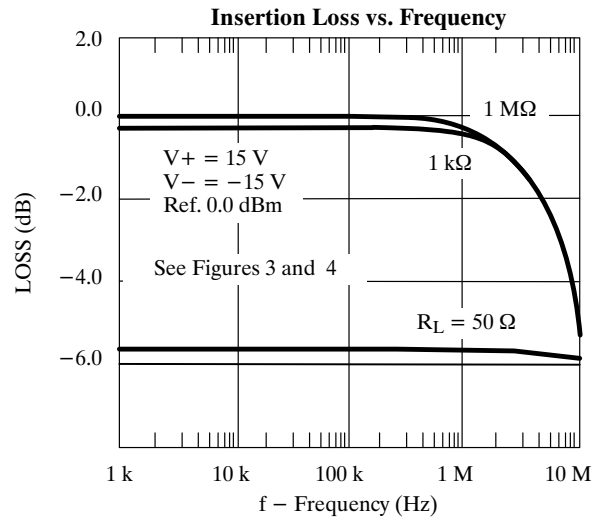
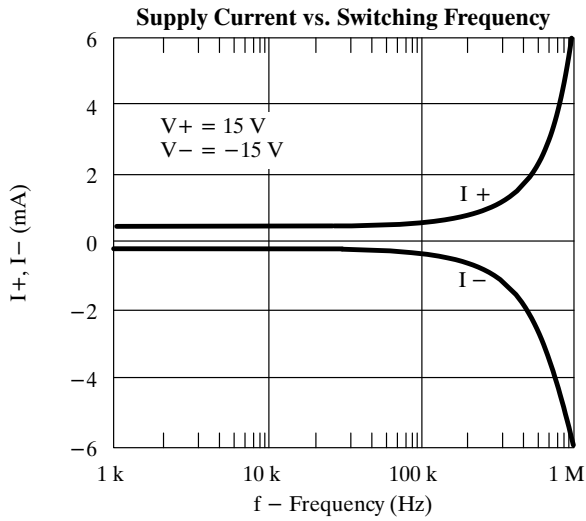

Schematic Diagram (Typical Channel)

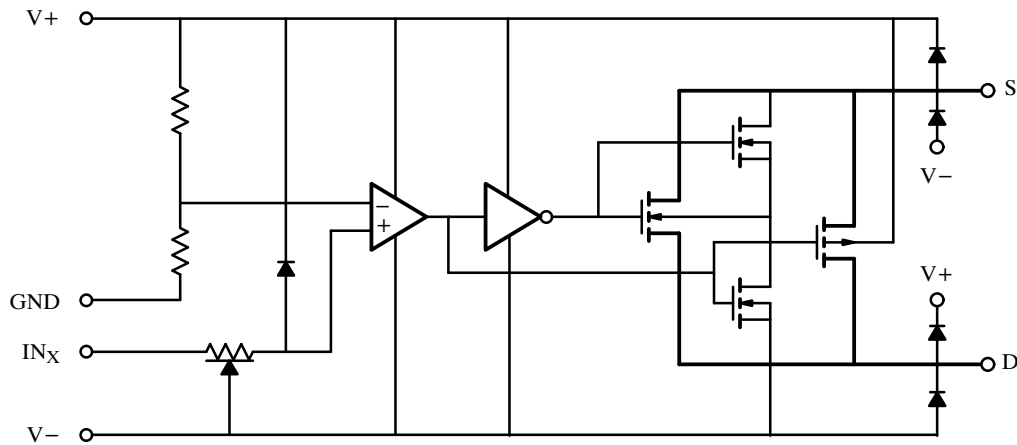

Figure 1.

Test Circuits

V_O is the steady state output with switch on. Feedthrough via gate capacitance may result in spikes at leading and trailing edge of output wave

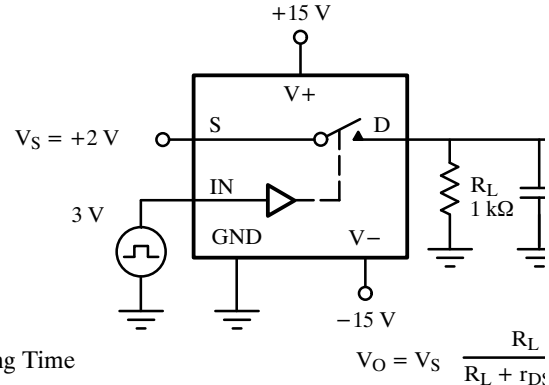
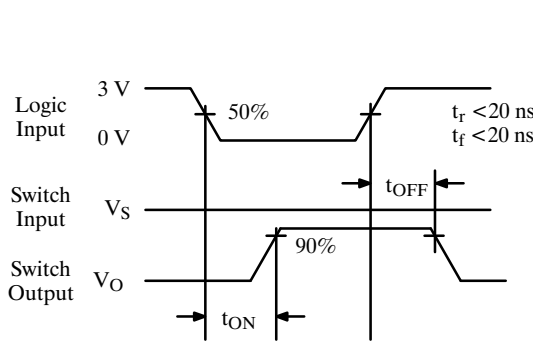

Figure 2. Switching Time

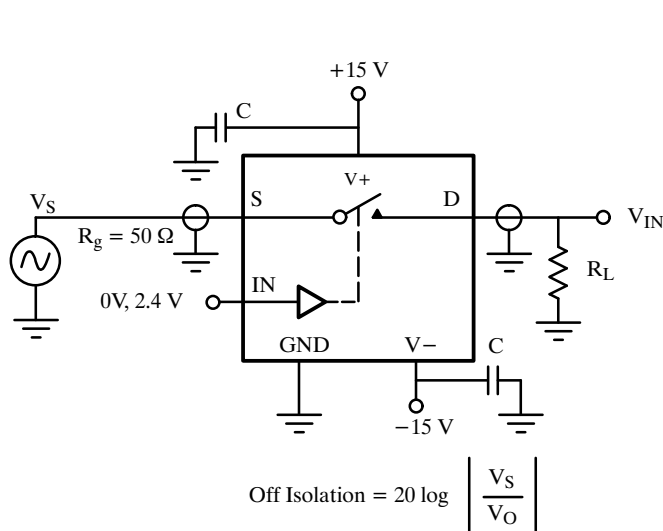

Figure 3. Off Isolation

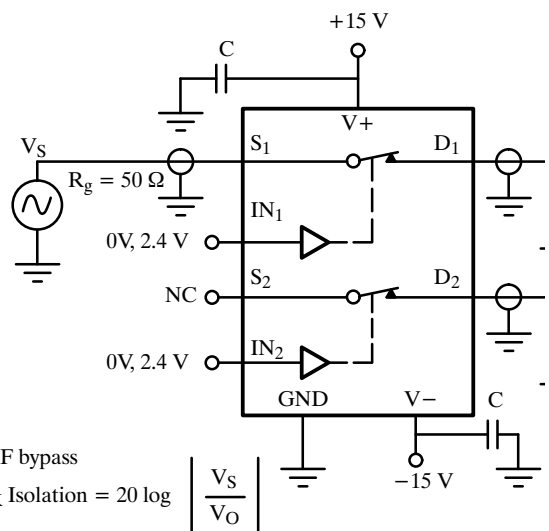
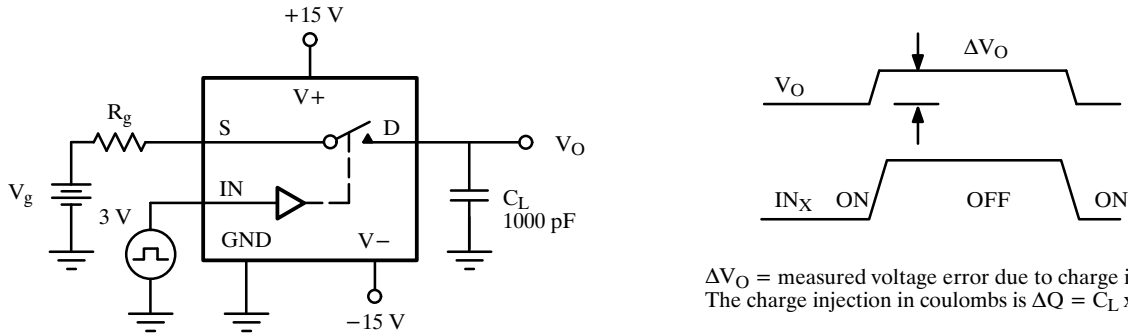

Figure 4. Channel-to-Channel Cross

DG201A/202

Test Circuits (Cont'd)



ΔV_O = measured voltage error due to charge injection
 The charge injection in coulombs is $\Delta Q = C_L \times \Delta V_O$

Figure 5. Charge Injection

Application Hints^a

V+ Positive Supply Voltage (V)	V- Negative Supply Voltage (V)	V _{IN} Logic Input Voltage V _{INH(min)} /V _{INL(max)} (V)	V _S or V _D Analog Voltage Range (V)
15	-15	2.4/0.8	-15 to 15
10	-12	2.4/0.8	-12 to 12
12	-10	2.2/0.6	-10 to 10
8 ^b	-8	2.0/0.5	-8 to 8

Notes

- a. Application Hints are for DESIGN AID ONLY, not guaranteed and not subject to production testing.
- b. Operation below ± 8 V is not recommended.

Applications

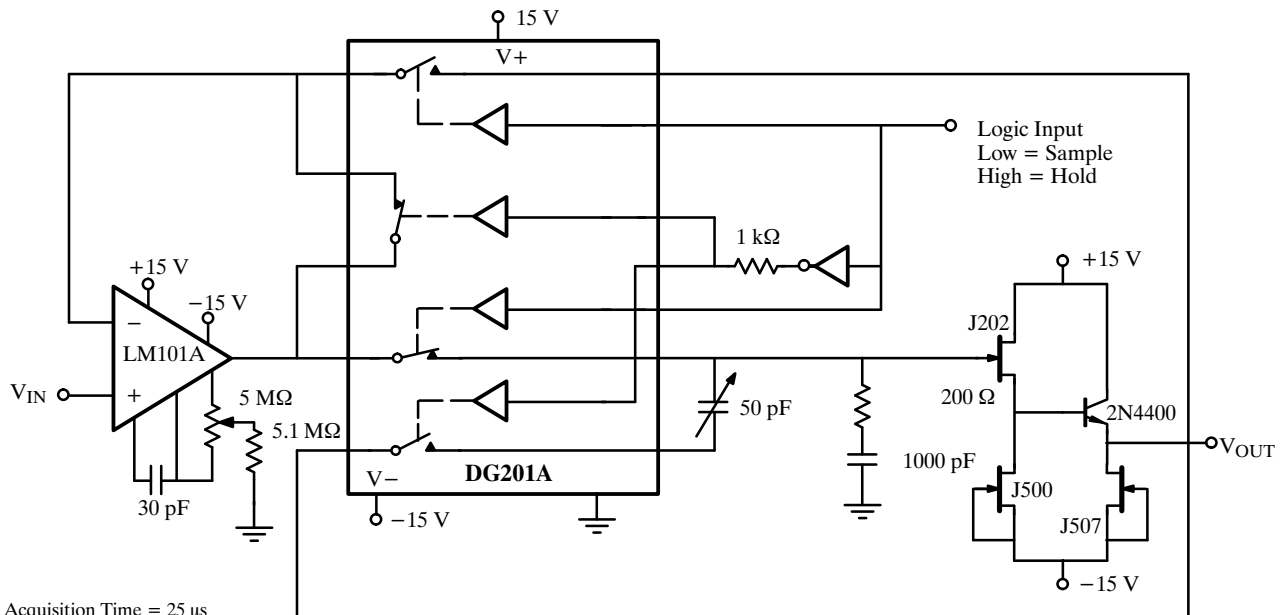

Acquisition Time = 25 μ s
 Aperture Time = 1 μ s
 Sample to Hold Offset = 5 mV
 Droop Rate = 5 mV/s

Figure 6. Sample-and-Hold

Applications (Cont'd)

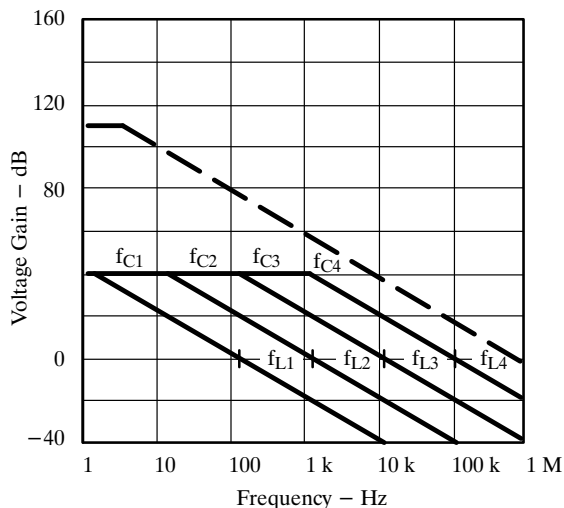
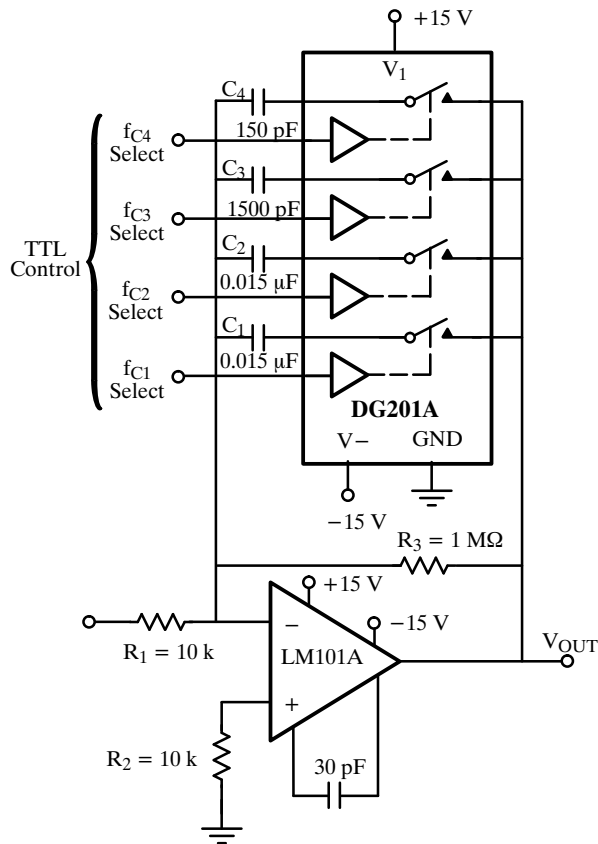

$$A_L \text{ (Voltage Gain Below Break Frequency)} = \frac{R_3}{R_1} = 100 \text{ (40 dB)}$$

$$f_C \text{ (Break Frequency)} = \frac{1}{2\pi R_3 C_X}$$

$$f_L \text{ (Unity Gain Frequency)} = \frac{1}{2\pi R_1 C_X}$$

$$\text{Max Attenuation} = \frac{f_{DS(on)}}{10 \text{ k}} \approx -40 \text{ dB}$$

Figure 7. Active Low Pass Filter with Digitally Selected Break Frequency

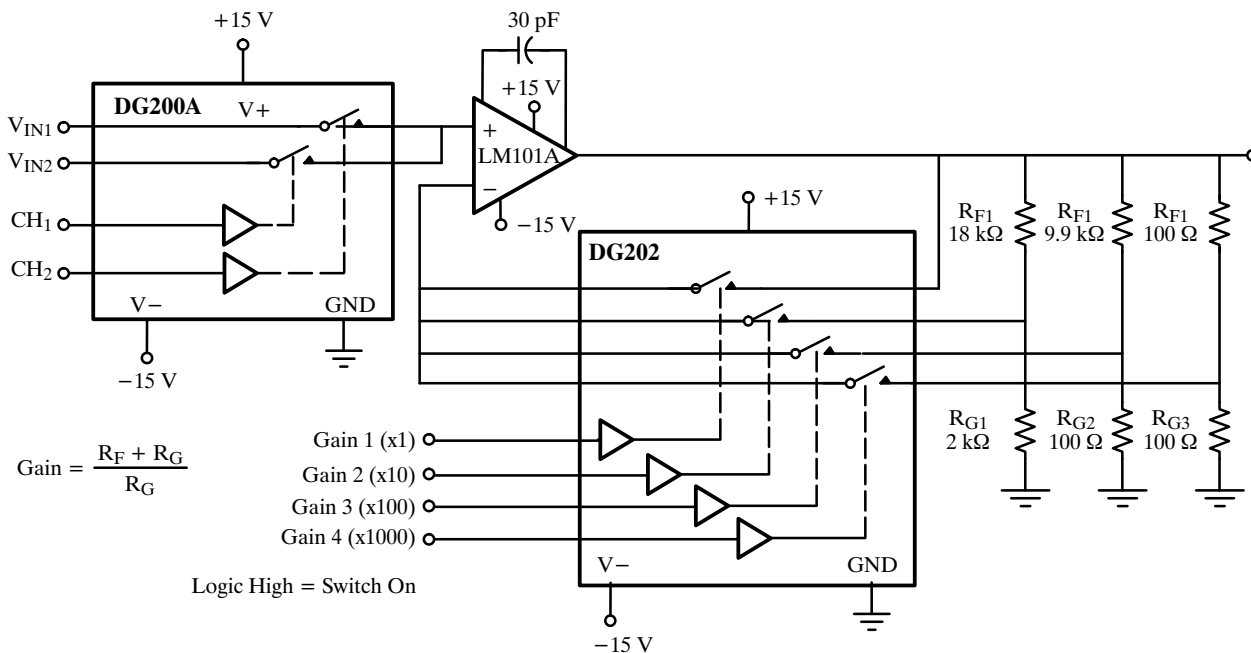

$$\text{Gain} = \frac{R_F + R_G}{R_G}$$

Logic High = Switch On

Figure 8. A Precision Amplifier with Digitally Programmable Input and Gains